

THESE WINDOWS ARE RATED FOR SMALL MISSILE IMPACT.  
F.B.C. APPROVED IMPACT RESISTANT SHUTTERS REQUIRED  
FOR INSTALLATIONS UP TO 30 FT. OF GRADE.  
SHUTTERS NOT REQD. FOR INSTALLATIONS ABOVE 30 FT. OF GRADE.

**ES-H340 (S.M.I.)  
THERMAL ALUMINUM SINGLE HUNG WINDOW**

DESIGN LOAD RATINGS FOR THESE WINDOWS TO BE AS PER  
CHARTS SHOWN ON SHEET 2.

APPROVAL APPLIES TO SINGLE UNITS OR SIDE BY SIDE  
COMBINATIONS OF S.H./S.H. OR SINGLE HUNG WITH OTHER  
WINDOW TYPES IN MODULES OF TWO OR MORE WINDOWS USING  
F.B.C. APPROVED MULLIONS IN BETWEEN.  
LOWER DESIGN PRESSURE FROM WINDOWS OR MULLION APPROVAL  
WILL APPLY TO ENTIRE SYSTEM.

THIS PRODUCT HAS BEEN DESIGNED AND TESTED TO COMPLY WITH THE  
REQUIREMENTS OF THE 2020 (7TH EDITION)/2023 (8TH EDITION) FLORIDA  
BUILDING CODE INCLUDING HIGH VELOCITY HURRICANE ZONE (HVHZ).

1BY OR 2BY WOOD BUCKS & BUCK FASTENERS BY OTHERS, MUST BE  
DESIGNED AND INSTALLED ADEQUATELY TO TRANSFER APPLIED PRODUCT  
LOADS TO THE BUILDING STRUCTURE.

ANCHORS SHALL BE CORROSION RESISTANT, SPACED AS SHOWN ON DETAILS  
AND INSTALLED PER MANUF'S INSTRUCTIONS. SPECIFIED EMBEDMENT TO BASE  
MATERIAL SHALL BE BEYOND WALL DRESSING OR STUCCO.

A LOAD DURATION INCREASE IS USED IN DESIGN OF ANCHORS INTO WOOD ONLY.  
ALL SHIMS TO BE HIGH IMPACT, NON-METALLIC AND NON-COMPRESSIBLE.

MATERIALS INCLUDING BUT NOT LIMITED TO STEEL/METAL SCREWS, THAT  
COME INTO CONTACT WITH OTHER DISSIMILAR MATERIALS SHALL MEET THE  
REQUIREMENTS OF THE 2020/2023 FLORIDA BLDG. CODE & ADOPTED STANDARDS.

THIS PRODUCT APPROVAL IS GENERIC AND DOES NOT PROVIDE INFORMATION  
FOR A SITE SPECIFIC PROJECT, i.e. LIFE SAFETY OF THIS PRODUCT, ADEQUACY  
OF STRUCTURE RECEIVING THIS PRODUCT AND SEALING AROUND OPENING FOR  
WATER INFILTRATION RESISTANCE ETC.  
CONDITIONS NOT SHOWN IN THIS DRAWING ARE TO BE ANALYZED SEPARATELY,  
AND TO BE REVIEWED BY BUILDING OFFICIAL.

DESIGN LOADS SHOWN ARE BASED ON 'ALLOWABLE STRESS DESIGN (ASD)'.

MANUFACTURER'S LABEL SHALL BE LOCATED ON A READILY VISIBLE LOCATION  
IN ACCORDANCE WITH SECTION 1709.9.3 OF FLORIDA BUILDING CODE.  
LABELING TO COMPLY WITH SECTION 1709.9.2.

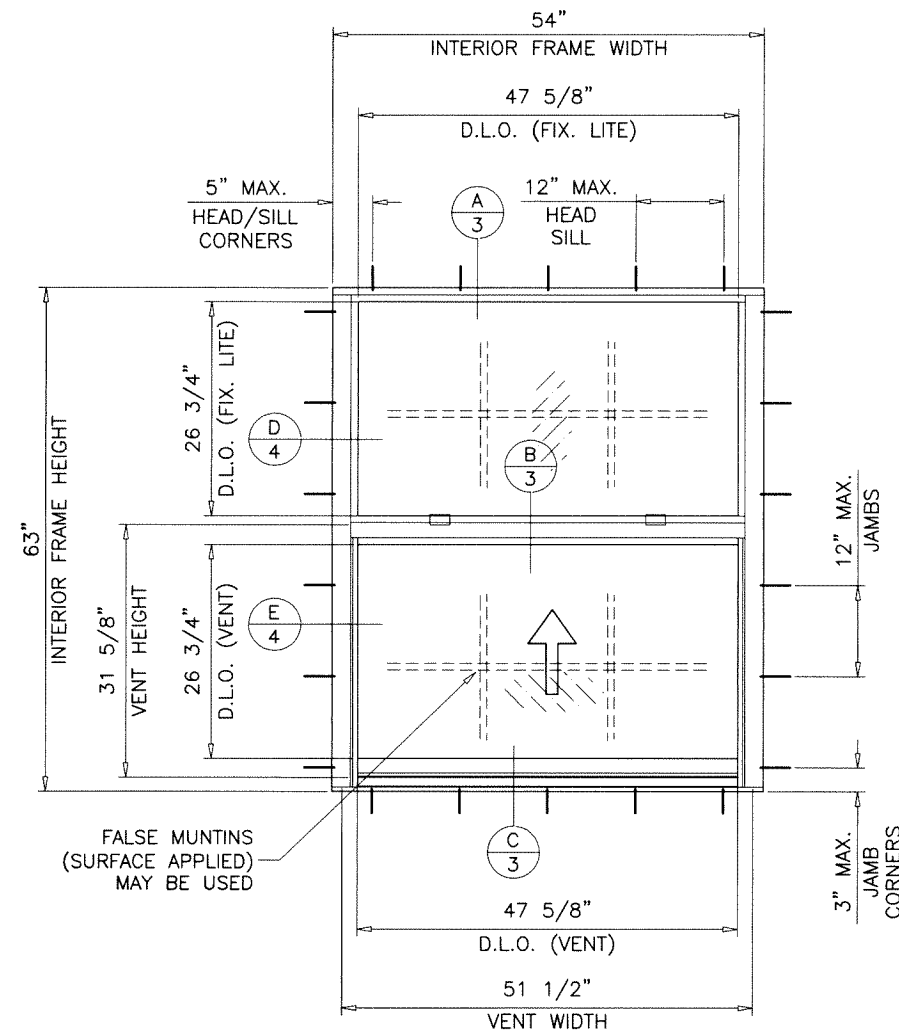

**TYPICAL ELEVATION**

EQUAL LITES

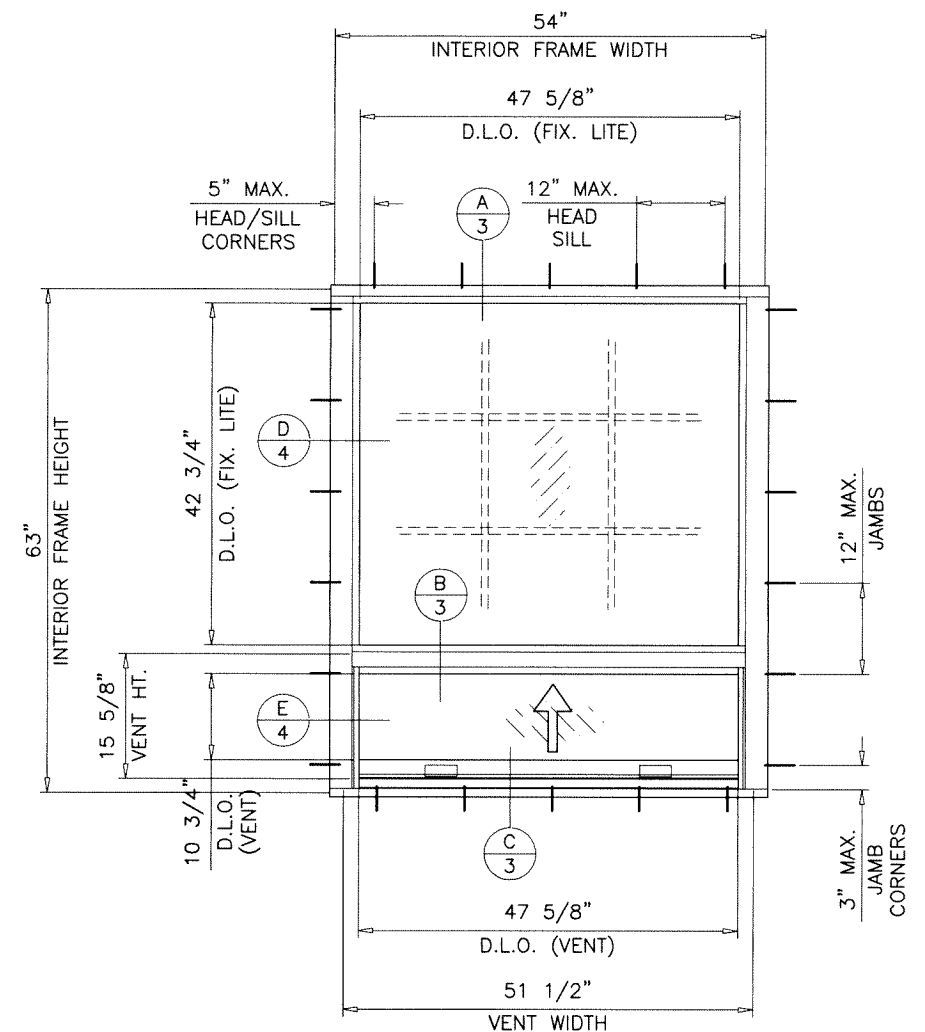

**TYPICAL ELEVATION**

UNEQUAL LITES (ORIEL TYPES)

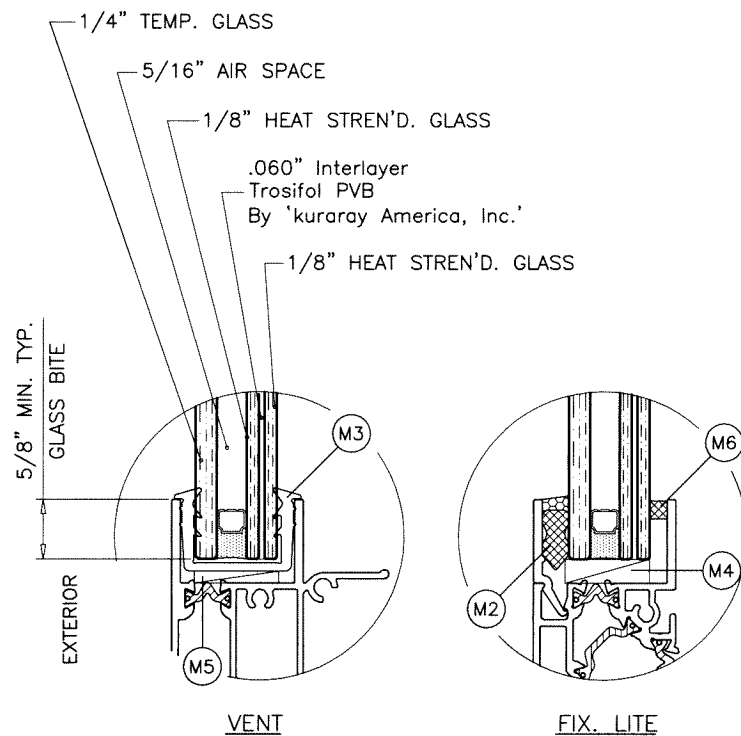

**GLAZING DETAILS**

7/8" OVERALL NOM. THK.

**5/16" AIR SPACE CONSISTING OF:**

- SPACER:**  
'HELIMA' LOW PROFILE ALUMINUM SPACER  
BY 'LINGERMANN GMBH'  
AROUND THE PERIMETER OF THE GLASS.  
**PERIMETER SEALANT:**  
SILICONE  
DOWSIL 791  
GE 2000

- A- CONTRACTOR TO BE RESPONSIBLE FOR THE SELECTION, PURCHASE AND  
INSTALLATION OF THIS PRODUCT BASED ON THIS PRODUCT EVALUATION  
PROVIDED HE/SHE DOES NOT DEVIATE FROM THE CONDITIONS DETAILED  
ON THIS DOCUMENT.  
B- THIS PRODUCT EVALUATION DOCUMENT WILL BE CONSIDERED INVALID IF  
ALTERED BY ANY MEANS.  
C- SITE SPECIFIC PROJECTS SHALL BE PREPARED BY A FLORIDA REGISTERED  
ENGINEER OR ARCHITECT WHICH WILL BECOME THE ENGINEER OF RECORD (E.O.R.)  
FOR THE PROJECT AND WHO WILL BE RESPONSIBLE FOR THE PROPER  
USE OF THE P.E.D. ENGINEER OF RECORD, ACTING AS A DELEGATED  
ENGINEER TO THE P.E.D. ENGINEER SHALL SUBMIT TO THIS LATTER THE SITE  
SPECIFIC DRAWINGS FOR REVIEW.  
D- THIS P.E.D. SHALL BEAR THE DATE AND ORIGINAL SEAL AND SIGNATURE OF  
THE PROFESSIONAL ENGINEER OF RECORD THAT PREPARED IT.

Sealed: 10/18/2023

FL #17892

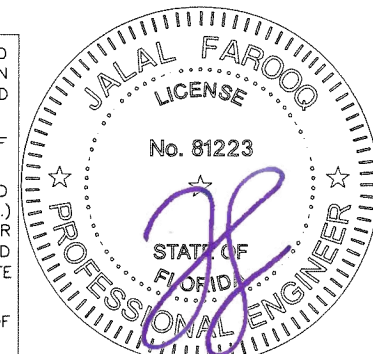

ES-H340 THERMAL ALUM SINGLE HUNG WDW. (S.M.I.)

**E.S. WINDOWS, LLC**  
3550 N.W. 49 STREET  
MIAMI, FL. 33142  
TEL. (305) 638-5151 FAX. (305) 638-5158

no	date	by	description
A	09.30.20		UPDATED TO 2020 FBC
B	09.08.23		UPDATED TO 2023 FBC

date: 04-12-12  
scale: 1/2"=1'-0"  
dr. by: TARIQ  
chk. by:

drawing no.  
**20-41F**

sheet 1 of 9

**af c**  
**AL-FAROOQ CORPORATION**  
ENGINEERS & PRODUCT DEVELOPMENT  
9360 SUNSET DRIVE, SUITE 220  
MIAMI, FLORIDA 33173  
TEL. (305) 264-8100 FAX. (305) 262-6978  
(C.A.N. 3538)

COMP-ANL\20-41F-ES

EQUAL LITES WINDOWS DESIGN LOAD CAPACITY - PSF			
INTERIOR FRAME DIMS.		INSUL. LAM. GLASS	
WIDTH	HEIGHT	EXT.(+)	INT.(-)
18-1/8"	25" (3)	80.0	90.0
25-1/2"		80.0	90.0
31"		80.0	90.0
36"		80.0	90.0
39"		80.0	90.0
43"		80.0	90.0
47"		80.0	90.0
52-1/8"		80.0	90.0
54"		80.0	90.0
18-1/8"	37-3/8" (4)	80.0	90.0
25-1/2"		80.0	90.0
31"		80.0	90.0
36"		80.0	90.0
39"		80.0	90.0
43"		80.0	90.0
47"	80.0	90.0	
52-1/8"	80.0	90.0	
54"	80.0	90.0	
18-1/8"	49-5/8" (5)	80.0	90.0
25-1/2"		80.0	90.0
31"		80.0	90.0
36"		80.0	90.0
39"		80.0	90.0
43"		80.0	90.0
47"	80.0	90.0	
52-1/8"	80.0	90.0	
54"	80.0	90.0	
18-1/8"	55" (5)	80.0	90.0
25-1/2"		80.0	90.0
31"		80.0	90.0
36"		80.0	90.0
39"		80.0	90.0
43"		80.0	90.0
47"	80.0	90.0	
52-1/8"	80.0	90.0	
54"	80.0	90.0	
18-1/8"	62" (6)	80.0	90.0
25-1/2"		80.0	90.0
31"		80.0	90.0
36"		80.0	90.0
39"		80.0	90.0
43"		80.0	90.0
47"	80.0	90.0	
52-1/8"	80.0	90.0	
54"	80.0	90.0	
18-1/8"	69" (7)	80.0	90.0
25-1/2"		80.0	90.0
31"		80.0	90.0
36"		80.0	90.0
39"		80.0	90.0
43"		80.0	90.0
47"	80.0	90.0	

EQUAL LITES WINDOWS DESIGN LOAD CAPACITY - PSF			
INTERIOR FRAME DIMS.		INSUL. LAM. GLASS	
WIDTH	HEIGHT	EXT.(+)	INT.(-)
18-1/8"	73-1/4" (7)	80.0	90.0
25-1/2"		80.0	90.0
31"		80.0	90.0
36"		80.0	90.0
39"		80.0	90.0
43"	80.0	90.0	
18-1/8"	75" (7)	80.0	90.0
25-1/2"		80.0	90.0
31"		80.0	90.0
36"		80.0	90.0
39"	80.0	90.0	
43"	80.0	90.0	
18-1/8"	81" (8)	80.0	90.0
25-1/2"		80.0	90.0
31"		80.0	90.0
36"		80.0	90.0
39"		80.0	90.0

\* NUMBER IN PARENTHESIS INDICATE  
MIN. NO. OF ANCHORS PER JAMB.

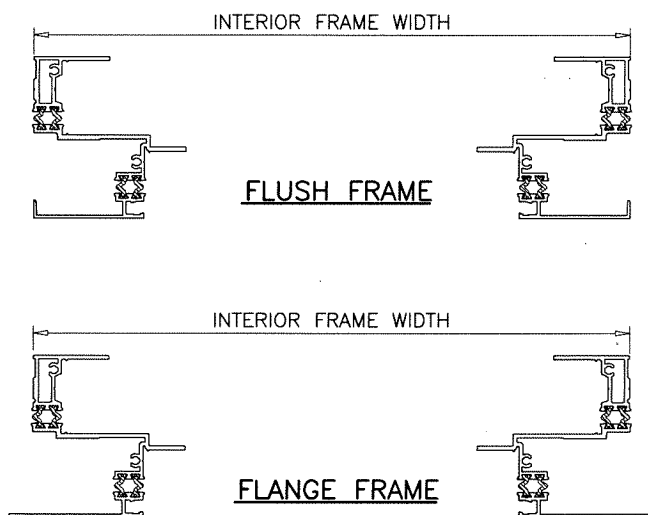
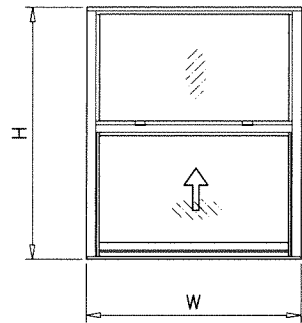

NOTE:  
GLASS CAPACITIES ON THIS SHEET ARE  
BASED ON ASTM E1300-09 (3 SEC. GUSTS)  
AND FLORIDA BUILDING COMMISSION  
DECLARATORY STATEMENT DCA05-DEC-219

UNEQUAL LITES (ORIEL TYPE) WDWS. DESIGN LOAD CAPACITY - PSF			
INTERIOR FRAME DIMS.		INSUL. LAM. GLASS	
WIDTH	HEIGHT	EXT.(+)	INT.(-)
18-1/8"	49-5/8" (5)	80.0	90.0
25-1/2"		80.0	90.0
31"		80.0	90.0
36"		80.0	90.0
39"		80.0	90.0
43"		80.0	90.0
47"		80.0	90.0
52-1/8"		80.0	90.0
54"		80.0	90.0
18-1/8"	55" (5)	80.0	90.0
25-1/2"		80.0	90.0
31"		80.0	90.0
36"		80.0	90.0
39"		80.0	90.0
43"		80.0	90.0
47"	80.0	90.0	
52-1/8"	80.0	90.0	
54"	80.0	90.0	
18-1/8"	62" (6)	80.0	90.0
25-1/2"		80.0	90.0
31"		80.0	90.0
36"		80.0	90.0
39"		80.0	90.0
43"		80.0	90.0
47"	80.0	90.0	
52-1/8"	80.0	90.0	
54"	80.0	88.9	
18-1/8"	69" (7)	80.0	90.0
25-1/2"		80.0	90.0
31"		80.0	90.0
36"		80.0	90.0
39"		80.0	90.0
43"		80.0	90.0
47"	80.0	90.0	
18-1/8"	73-1/4" (7)	80.0	90.0
25-1/2"		80.0	90.0
31"		80.0	90.0
36"		80.0	90.0
39"		80.0	90.0
43"	80.0	90.0	
18-1/8"	75" (7)	80.0	90.0
25-1/2"		80.0	90.0
31"		80.0	90.0
36"		80.0	90.0
39"		80.0	90.0
43"	80.0	90.0	
18-1/8"	81" (8)	80.0	90.0
25-1/2"		80.0	90.0
31"		80.0	90.0
36"		80.0	90.0
39"		80.0	90.0

\* NUMBER IN PARENTHESIS INDICATE  
MIN. NO. OF ANCHORS PER JAMB.

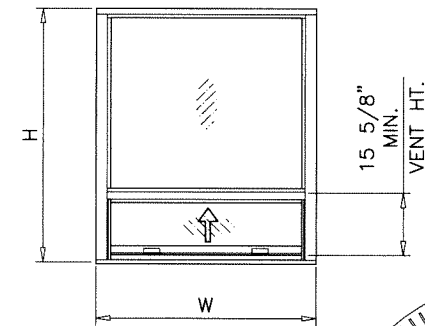

Sealed: 10/18/2023

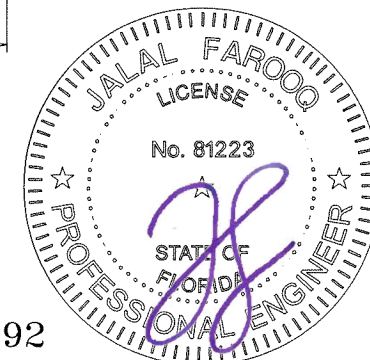

FL #17892

**af c**  
**AL-FAROOQ CORPORATION**  
ENGINEERS & PRODUCT DEVELOPMENT  
9360 SUNSET DRIVE, SUITE 220 (C.A.N. 3538)  
MIAMI, FLORIDA 33173  
TEL. (305) 264-8100 FAX. (305) 262-6978  
COMP-ANL\20-41F-ES

ES-H340 THERMAL ALUM SINGLE HUNG WDW. (S.M.I.)  
**E.S. WINDOWS, LLC**  
3550 N.W. 49 STREET  
MIAMI, FL. 33142  
TEL. (305) 638-5151 FAX. (305) 638-5158

revisions:	no	date	by	description
date:	04-12-12	scale:	1/2"=1'-0"	
dr. by:	TARIQ	chk. by:		
drawing no.	20-41F			
sheet	2 of 9			

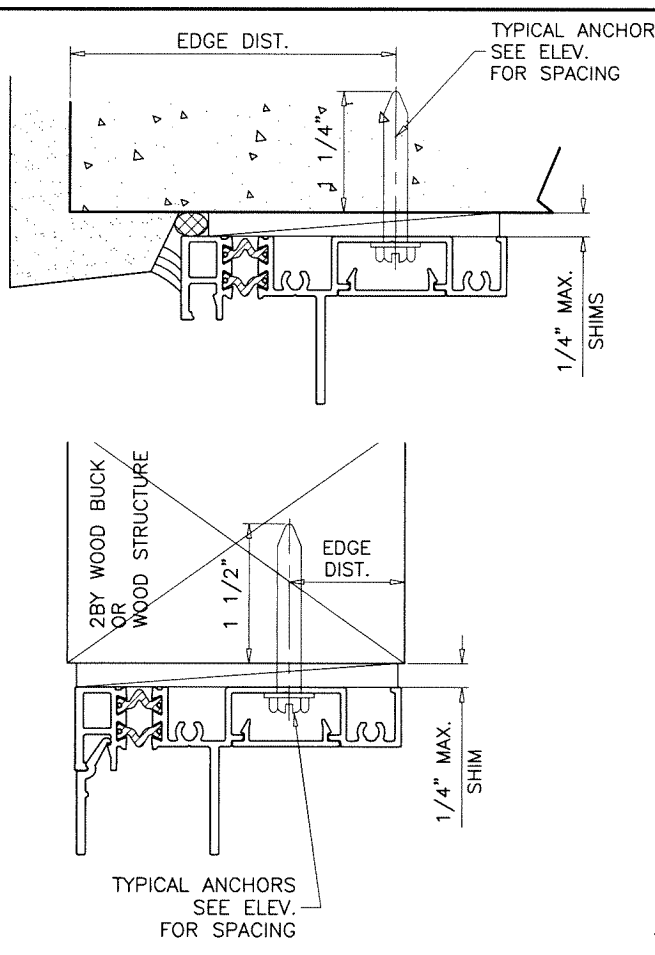
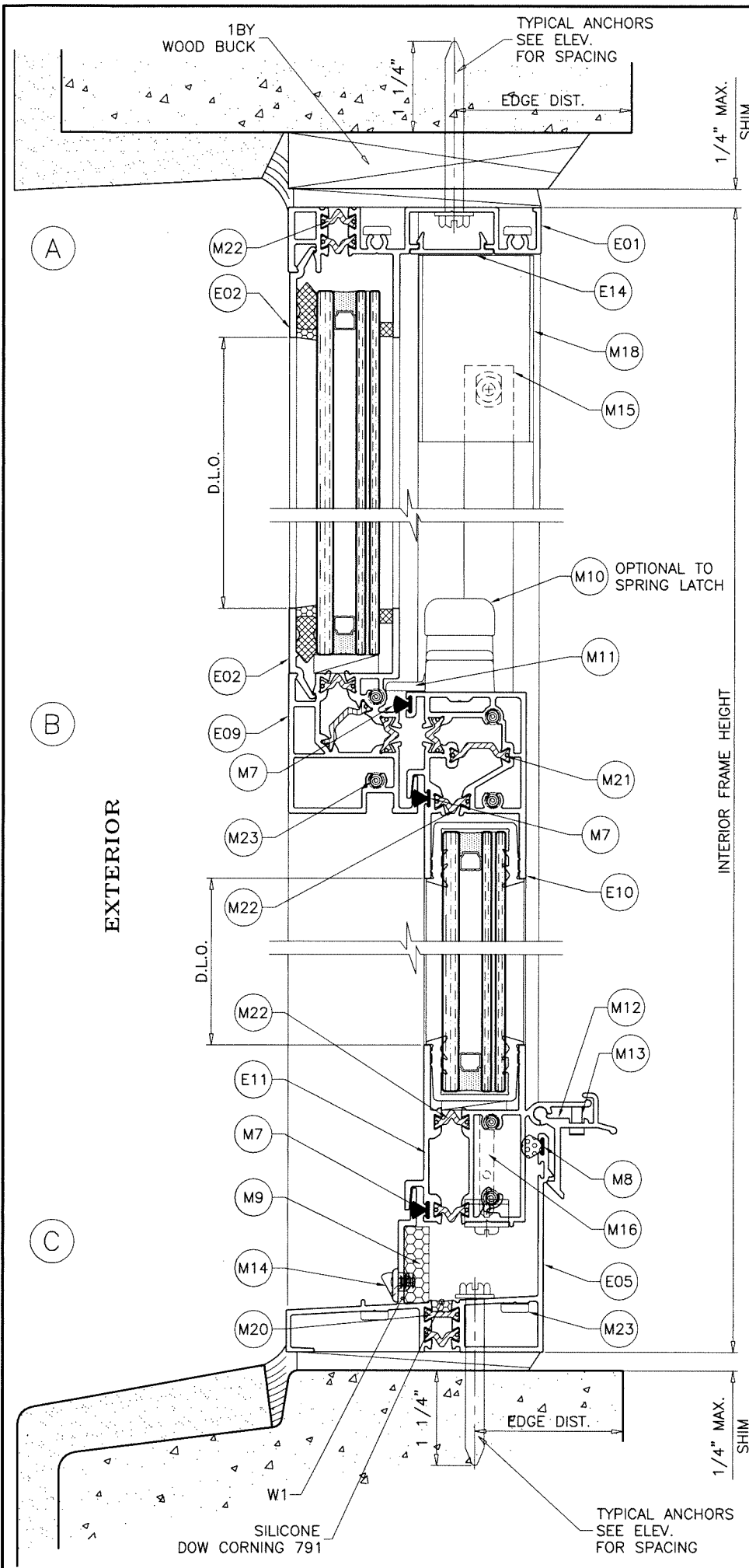

WOOD BUCKS AND METAL STRUCTURE NOT BY 'E.S. WINDOWS', MUST SUSTAIN LOADS IMPOSED BY GLAZING SYSTEM AND TRANSFER THEM TO THE BUILDING STRUCTURE.

**WEEPHOLES:**  
 W1 = 1-7/8" X 1/4" WEEPHOLES AT 6-1/2" FROM EACH END

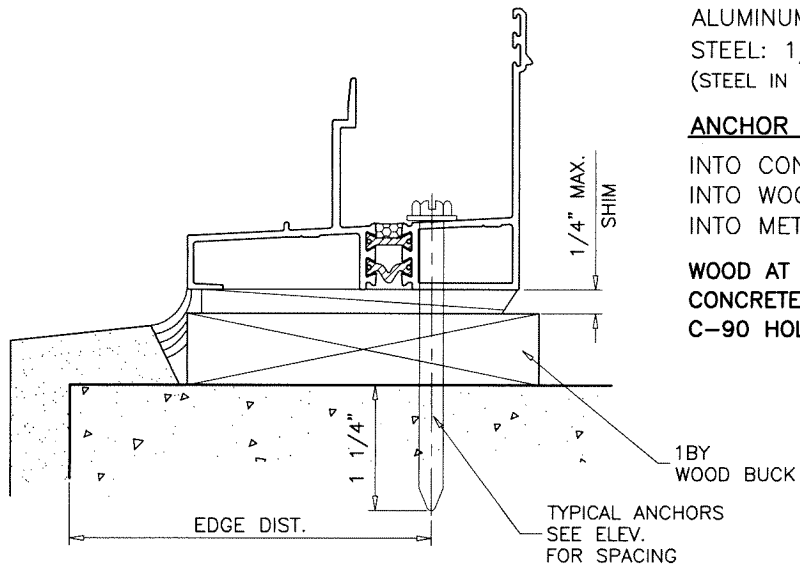

**TYPICAL ANCHORS:** SEE ELEV. FOR SPACING

**1/4" DIA. CRETE-FLEX SS4 BY 'DEWALT'** (Fu=190 KSI, Fy=127 KSI)

**1/4" DIA. AGGRE-GATOR 300 BY 'DEWALT'** (Fu=96 KSI, Fy=57 KSI)

**1/4" DIA. ULTRACON+ BY 'DEWALT'** (Fu=164 KSI, Fy=148 KSI)

INTO 2BY WOOD BUCKS OR WOOD STRUCTURES  
 1-1/2" MIN. PENETRATION INTO WOOD (HEAD/SILL/JAMBS)  
 THRU 1BY BUCKS INTO CONC. OR BLOCKS  
 1-1/4" MIN. EMBED INTO CONCRETE (HEAD/SILL/JAMBS)  
 1-1/4" MIN. EMBED INTO BLOCKS (JAMBS)

DIRECTLY INTO CONCRETE OR BLOCKS  
 1-1/4" MIN. EMBED INTO CONCRETE (HEAD/SILL/JAMBS)  
 1-1/4" MIN. EMBED INTO BLOCKS (JAMBS)

**1/4" DIA. ULTRACON SS4 410 BY 'DEWALT'** (Fu=190 KSI, Fy=164 KSI)

INTO 2BY WOOD BUCKS OR WOOD STRUCTURES  
 1-1/2" MIN. PENETRATION INTO WOOD (HEAD/SILL/JAMBS)  
 THRU 1BY BUCKS INTO CONC. OR BLOCKS  
 1-1/4" MIN. EMBED INTO CONCRETE (HEAD/SILL/JAMBS)  
 1-1/4" MIN. EMBED INTO GROUT-FILLED BLOCKS (JAMBS)

DIRECTLY INTO CONCRETE OR BLOCKS  
 1-1/4" MIN. EMBED INTO CONCRETE (HEAD/SILL/JAMBS)  
 1-1/4" MIN. EMBED INTO GROUT-FILLED BLOCKS (JAMBS)

**1/4" DIA. BI-FLEX 300 SELF DRILLING SCREWS BY 'DEWALT'**

**1/4" DIA. DRIL-FLEX SELF DRILLING SCREWS BY 'DEWALT'** (Fu=100 KSI, Fy= 65 KSI)

INTO F.B.C. APPROVED MULLIONS  
 OR  
 INTO METAL STRUCTURES (HEAD/SILL/JAMBS)  
 (3) THREADS MIN. TO EXTEND BEYOND METAL THICKNESS  
 ALUMINUM: 1/8" THK. MIN. (6063-T5 MIN.)  
 STEEL: 1/8" THK. MIN. (Fy = 36 KSI MIN.)  
 (STEEL IN CONTACT WITH ALUMINUM TO BE PLATED OR PAINTED)

**ANCHOR EDGE DISTANCES**  
 INTO CONCRETE AND BLOCKS = 2-1/2" MIN.  
 INTO WOOD STRUCTURE = 1" MIN.  
 INTO METAL STRUCTURE = 3/4" MIN.

WOOD AT HEAD, SILL OR JAMBS SG = 0.55 MIN.  
 CONCRETE AT HEAD, SILL OR JAMBS f'c = 3000 PSI MIN.  
 C-90 HOLLOW/FILLED BLOCK AT JAMBS f'm = 2000 PSI MIN.

Sealed: 10/18/2023



FL #17892

**AL-FAROOQ CORPORATION**  
 ENGINEERS & PRODUCT DEVELOPMENT  
 9360 SUNSET DRIVE, SUITE 220  
 MIAMI, FLORIDA 33173  
 TEL. (305) 262-6978  
 FAX. (305) 264-8100

ES-H340 THERMAL ALUM SINGLE HUNG WDW. (S.M.I.)

**E.S. WINDOWS, LLC**  
 3550 N.W. 49 STREET  
 MIAMI, FL. 33142  
 TEL. (305) 638-5151 FAX. (305) 638-5158

revisions:	no	date	description

date: 04-12-12  
 scale: 1/2" = 1"  
 dr. by: TARIQ  
 chk. by:

drawing no.  
**20-41F**

sheet 3 of 9

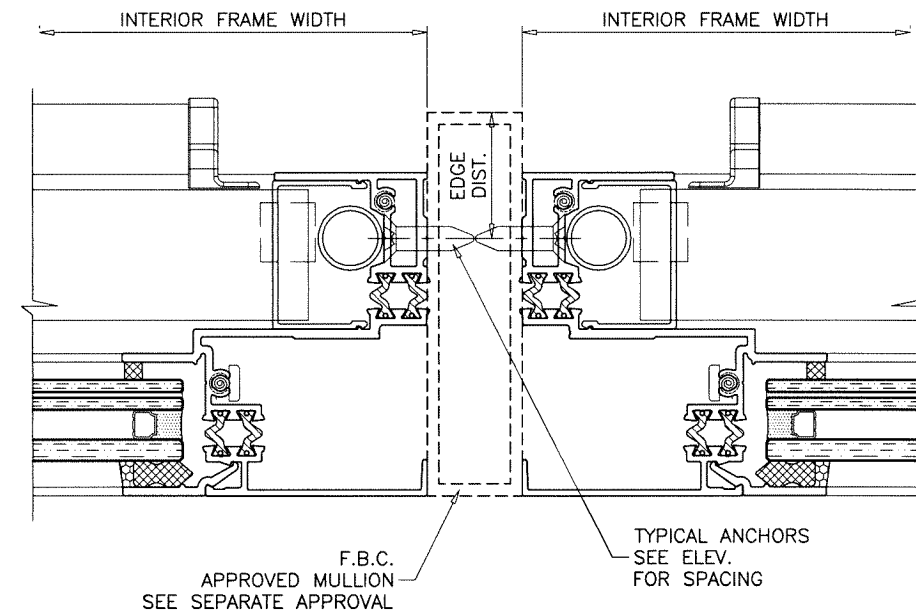
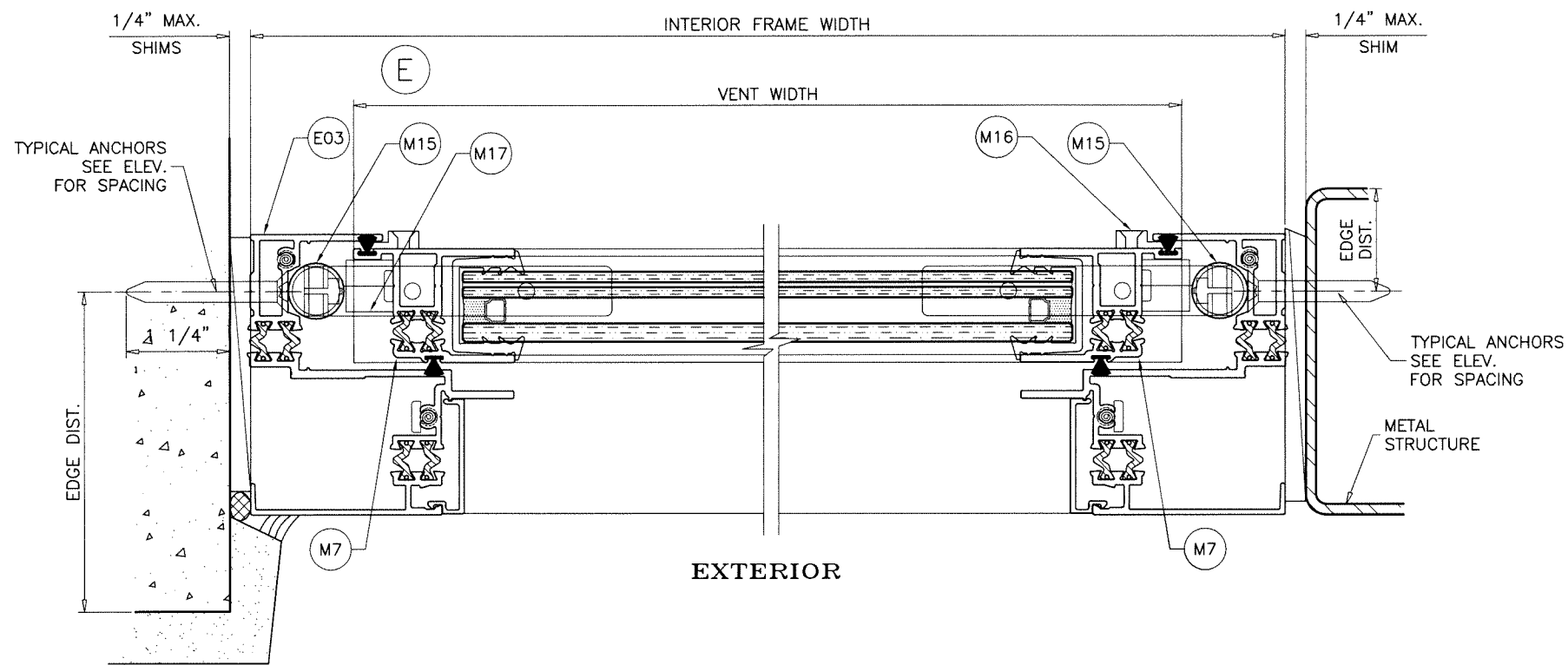
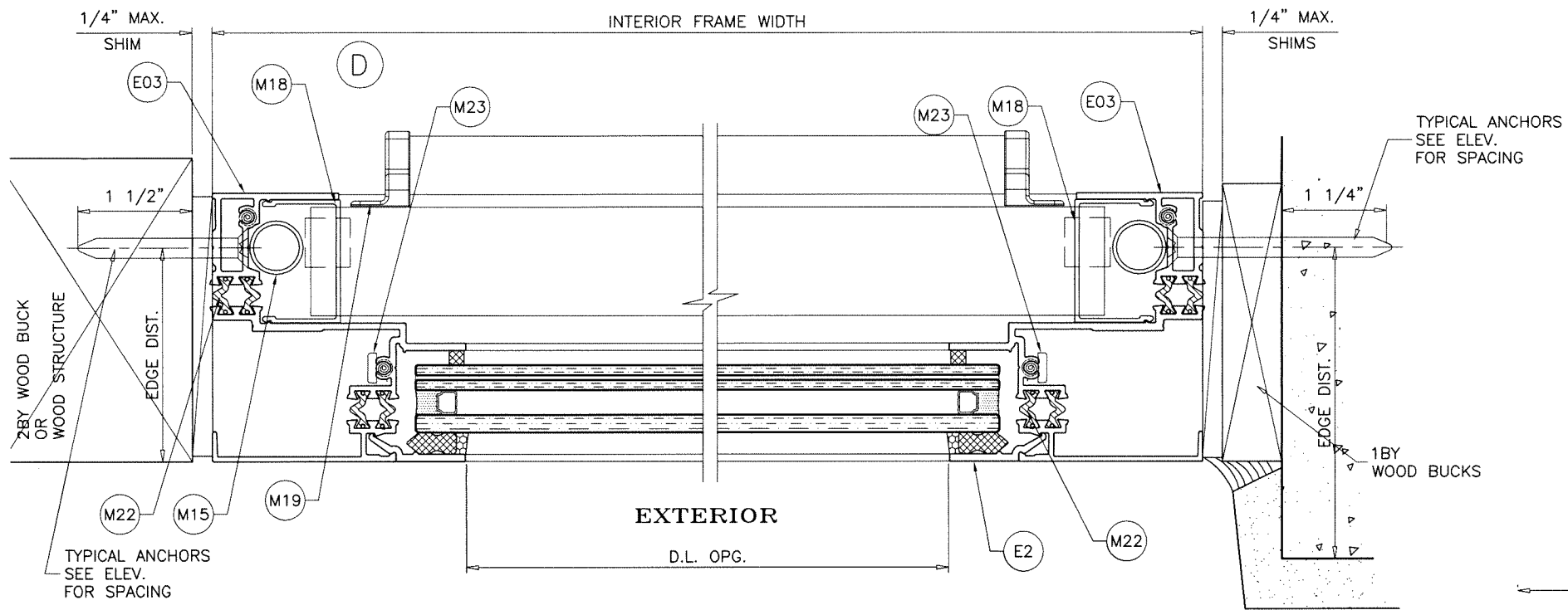

Sealed: 10/18/2023



FL #17892

**af c**  
**AL-FAROOQ CORPORATION**  
ENGINEERS & PRODUCT DEVELOPMENT  
9360 SUNSET DRIVE, SUITE 220 (C.A.N. 3538)  
MIAMI, FLORIDA 33173  
TEL. (305) 264-8100 FAX. (305) 262-6978  
COMP-ANI\20-41F-ES

ES-H340 THERMAL ALUM SINGLE HUNG WDW. (S.M.I.)  
**E.S. WINDOWS, LLC**  
3550 N.W. 49 STREET  
MIAMI, FL. 33142  
TEL. (305) 638-5151 FAX. (305) 638-5158

revisions:	no	date	by	description

date: 04-12-12  
scale: 1/2" = 1"  
dr. by: TARIQ  
chk. by:

drawing no.  
**20-41F**

sheet 4 of 9

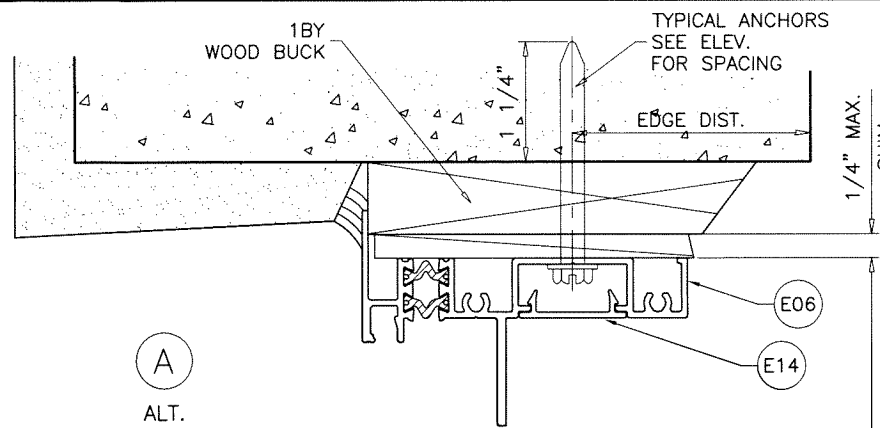

A  
ALT.

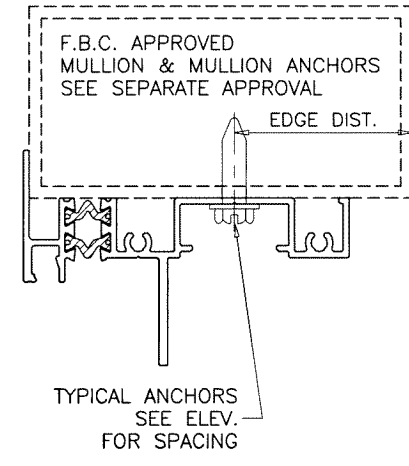
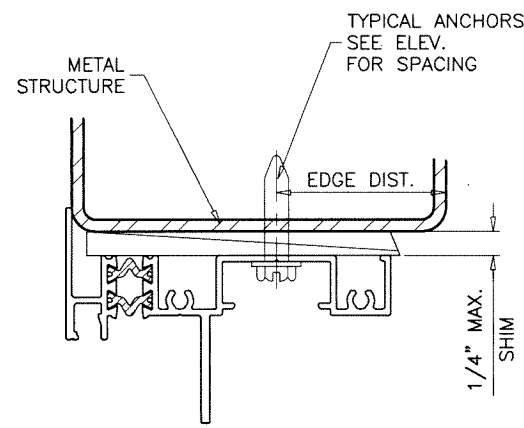
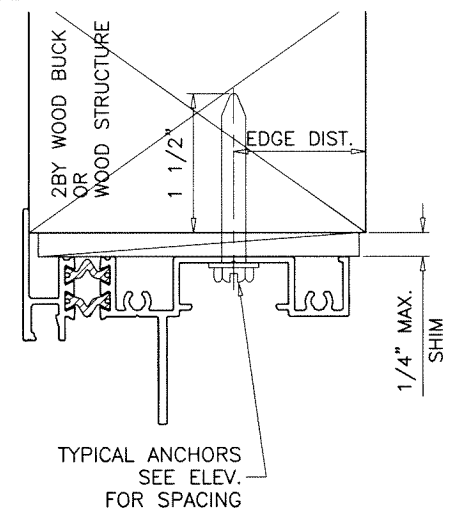

INTERIOR FRAME HEIGHT

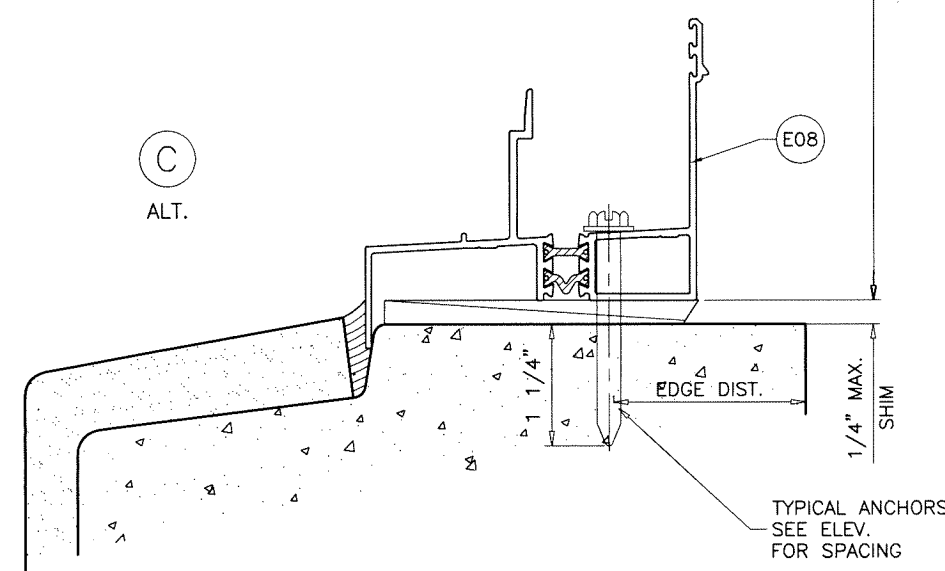

C  
ALT.

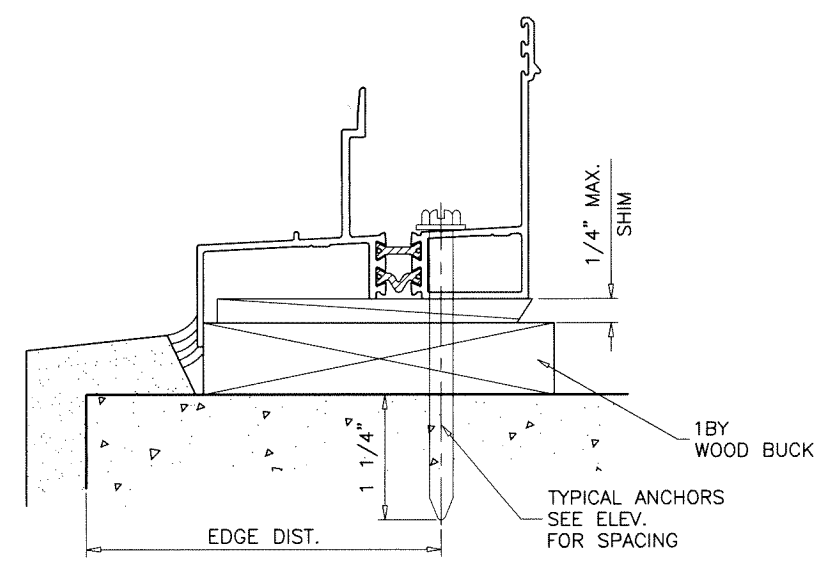

INSTALLATION DETAILS WITH FLANGE FRAMES

Sealed: 10/18/2023

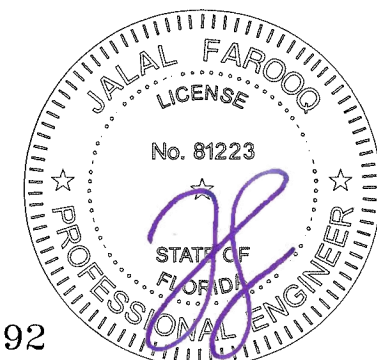

FL #17892

**af c**  
**AL-FAROOQ CORPORATION**  
 ENGINEERS & PRODUCT DEVELOPMENT  
 9360 SUNSET DRIVE, SUITE 220 (C.A.N. 3538)  
 MIAMI, FLORIDA 33173 TEL. (305) 262-6978  
 TEL. (305) 264-8100 FAX. (305) 262-6978  
 COMP-ANL\20-41F-ES

ES-H340 THERMAL ALUM SINGLE HUNG WDW. (S.M.I.)  
**E.S. WINDOWS, LLC**  
 3550 N.W. 49 STREET (C.A.N. 3538)  
 MIAMI, FL. 33142 TEL. (305) 638-5151 FAX. (305) 638-5158

no	date	by	description

date: 04-12-12  
 scale: 1/2" = 1"  
 dr. by: TARIQ  
 chk. by:  
 drawing no.  
**20-41F**  
 sheet 5 of 9

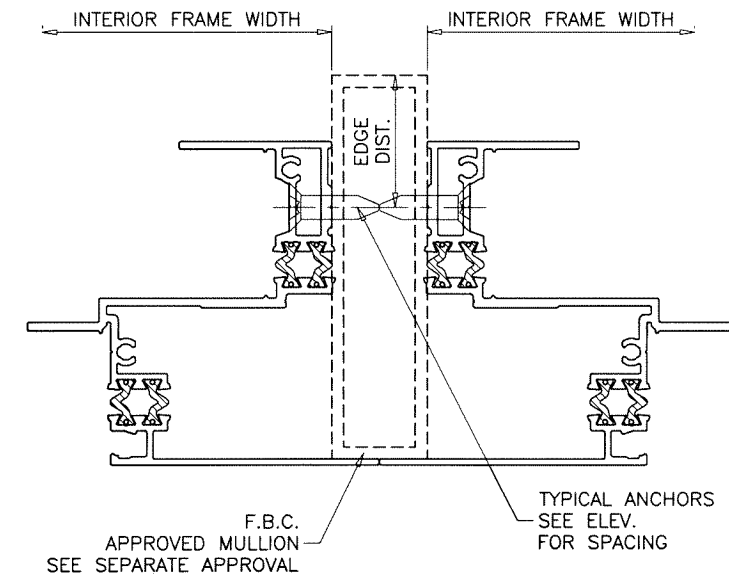
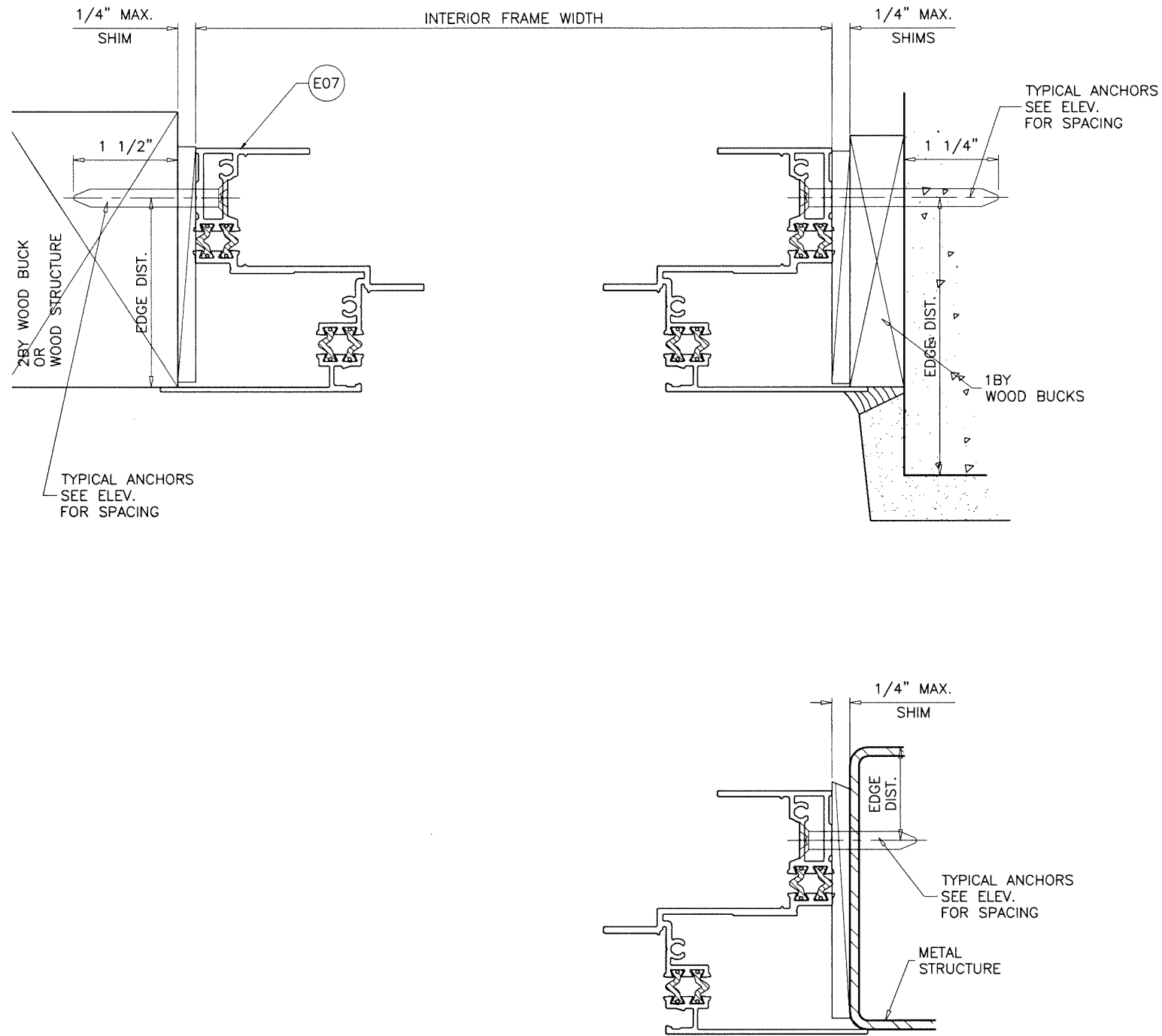

**INSTALLATION DETAILS WITH FLANGE FRAMES**

Sealed: 10/18/2023

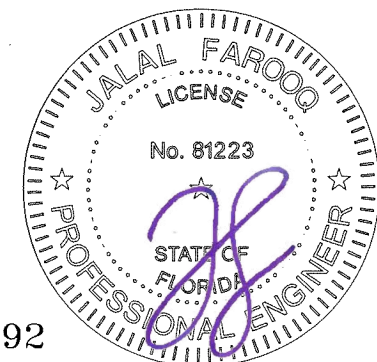

FL #17892

**afc**  
**AL-FAROOQ CORPORATION**  
 ENGINEERS & PRODUCT DEVELOPMENT  
 9360 SUNSET DRIVE, SUITE 220  
 MIAMI, FLORIDA 33173 (C.A.N. 3538)  
 TEL. (305) 264-8100 FAX. (305) 262-6978  
 COMP-ANL\20-41F-ES

ES-H340 THERMAL ALUM SINGLE HUNG WDW. (S.M.I.)  
**E.S. WINDOWS, LLC**  
 3550 N.W. 49 STREET  
 MIAMI, FL. 33142  
 TEL. (305) 638-5151 FAX. (305) 638-5158

no	date	by	description

date: 04-12-12  
 scale: 1/2" = 1"  
 dr. by: TARIQ  
 chk. by:   
 drawing no. 20-41F  
 sheet 6 of 9

ITEM #	PART #	REQD.	DESCRIPTION	MATERIAL	MANF./SUPPLIER/REMARKS
E01	ES-H340-501	1	FLUSH FRAME HEAD	6063-T6	-
E02	ES-H340-003	4/ LITE	GLASS STOP	6063-T6	-
E03	ES-H340-505	2	FLUSH FRAME JAMB	6063-T6	-
E04	ES-H340-007	AS REQD.	SCREEN ADAPTER/COVER	6063-T5	-
E05	ES-H340-503	1	FLUSH FRAME SILL	6063-T6	-
E06	ES-H340-502	1	FLANGE FRAME HEAD	6063-T6	-
E07	ES-H340-506	2	FLANGE FRAME JAMB	6063-T6	-
E08	ES-H340-504	1	FLANGE FRAME SILL	6063-T6	-
E09	ES-H340-507	1	FIXED INTERLOCK	6063-T6	-
E10	ES-H340-508	1	VENT INTERLOCK	6063-T6	-
E11	ES-H340-509	1	BOTTOM RAIL	6063-T6	-
E12	ES-H340-510	2	JAMB STILE	6063-T6	-
E13	ES-H340-021	-	JAMB TRIM	6063-T5	-
E14	ES-9502	AS REQD.	HEAD FRAME COVER	6063-T5	-
M2	ES-H340-G02	AS REQD.	EXTERIOR GLAZING WEDGE (FIX. LITE)	EPDM	DUROMETER 60±5 SHORE A
M3	ES-H340-G01	AS REQD.	GLAZING GASKET (VENT)	EPDM	DUROMETER 60±5 SHORE A
M4	ES-21-B04A	AS REQD.	SETTING BLOCK (FIX. LITE)	EPDM	DUROMETER 80±5 SHORE A
M5	ES-7530-B01A	AS REQD.	SETTING BLOCK (VENT)	EPDM	DUROMETER 80±5 SHORE A
M6	-	AS REQD.	INTERIOR GLAZING TAPE	POLYURETHANE	THERMALBOND
M7	W23241NK	AS REQD.	PILE W'STRIPPING	-	-
M8	Q300T190	AS REQD.	Q-LONG W'STRIPPING	-	-
M9	WPSA	1/ WEEP	FOAM PAD, 2" X 1" X 5/8"	FOAM	OPEN CELL
M10	3032	2/ VENT	SWEEP LOCK	DIE CAST ALUM.	-
M11	ES1050-PL1	-	SWEEP LOCK FLAT BOLT	ST. STEEL	-
M12	SK08-4000.000	-	VENT LATCH INTERLOCK	DIE CAST ALUM	-
M13	ES-1012	-	LATCH SPRING LS 4050	ST. STEEL	-
M14	WA2L	-	WEEP HOLE COVER	RIGID PVC	-
M15	30-31	2/ VENT	ULTRA LIFT BALANCE	STEEL ROD	-
M16	-	2/ VENT	BALANCE GUIDE	NYLON	FASTENED W/ (1) #8 X 1/2" FH SMS
M17	21803	-	NON TILT	ST. STEEL	-
M18	ES-H340-P01	-	SASH STOP	RIGID PVC	-
M19	ES-1000-P1	-	NOTCH CAP	NYLON	-
M20	2310	-	INSULBAR 10MM FLAT	POLYAMIDE	ENSINGER
M21	1673	-	INSULBAR 20MM OFFSET	POLYAMIDE	ENSINGER
M22	-	-	INSULBAR 12MM OFFSET	POLYAMIDE	ENSINGER
M23	#10 X 1-1/4"	AS REQD.	ASSEMBLY FASTENERS	ST. STEEL	PH SMS
M24	#8 X 1/2"	-	NON TILT SCREWS	ST. STEEL	PH SMS
M25	#6 X 1/2"	-	BALANCE GUIDE SCREWS	ST. STEEL	FH SMS

**SEALANTS:**

FRAME AND VENT CORNERS AND INSTALLATION SCREWS AT SILL SEALED WITH WHITE/ALUMINUM COLORED GENERAL PURPOSE SILICONE SEALANT BY MACKLANBURG-DUNCAN.

Sealed: 10/18/2023



FL #17892

**af c**  
**AL-FAROOQ CORPORATION**  
 ENGINEERS & PRODUCT DEVELOPMENT  
 9360 SUNSET DRIVE, SUITE 220 (C.A.N. 3538)  
 MIAMI, FLORIDA 33173  
 TEL. (305) 264-8100 FAX. (305) 262-6978

ES-H340 THERMAL ALUM SINGLE HUNG WDW. (S.M.I.)  
**E.S. WINDOWS, LLC**  
 3550 N.W. 49 STREET  
 MIAMI, FL. 33142  
 TEL. (305) 638-5151 FAX. (305) 638-5158

no	date	by	description

date: 04-12-12  
 scale: 1/2" = 1"  
 dr. by: TARIQ  
 chk. by:

drawing no.  
**20-41F**  
 sheet 7 of 9

COMP-ANL\20-41F-ES

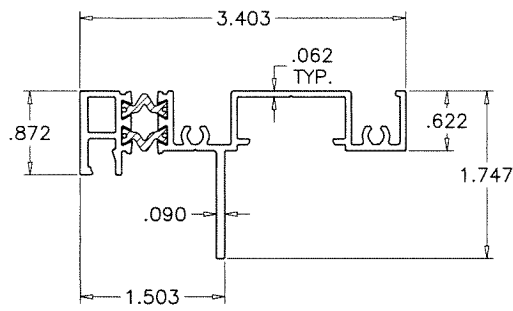

E01 FLUSH FRAME HEAD

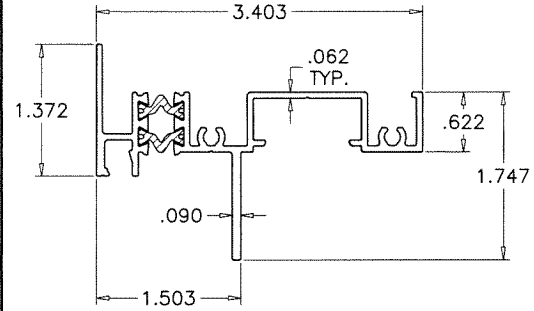

E06 FLANGE FRAME HEAD

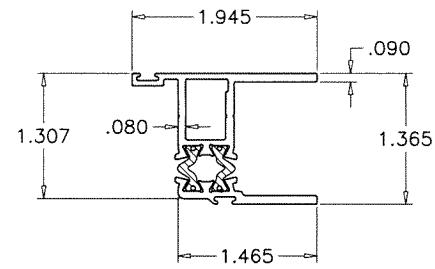

E12 VENT SIDE RAIL

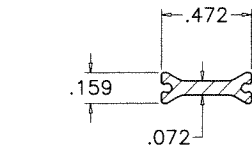

M20 10MM FLAT

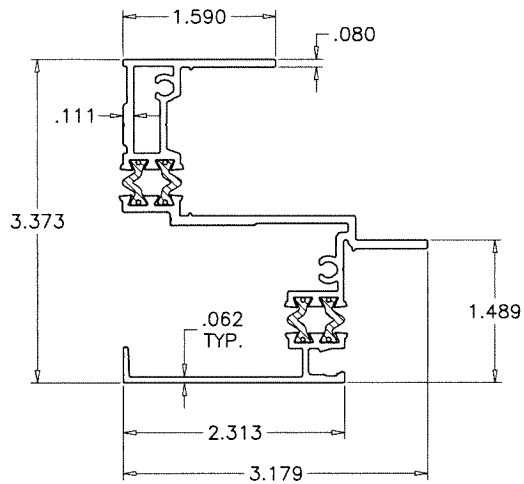

E03 FLUSH FRAME JAMB

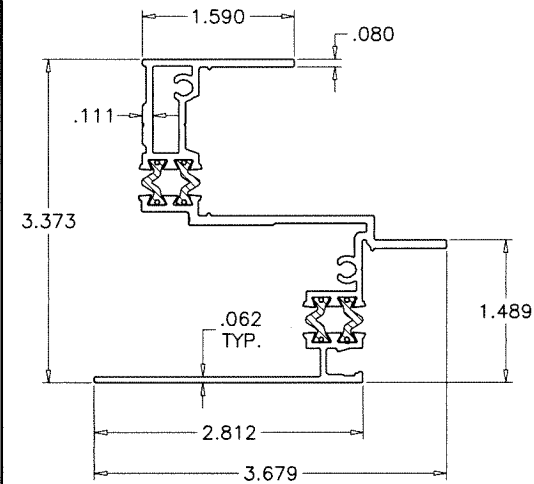

E07 FLANGE FRAME JAMB

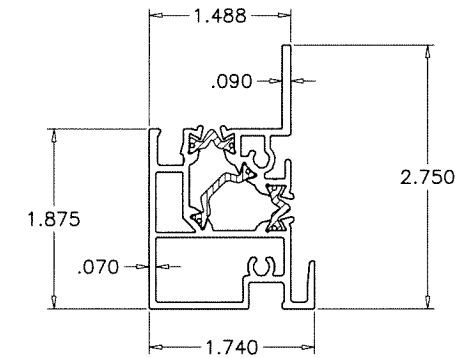

E09 FIX. MEETING RAIL

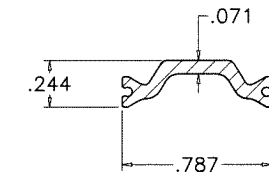

M21 20MM OFFSET

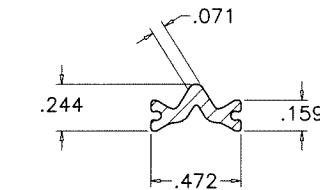

M22 12MM OFFSET

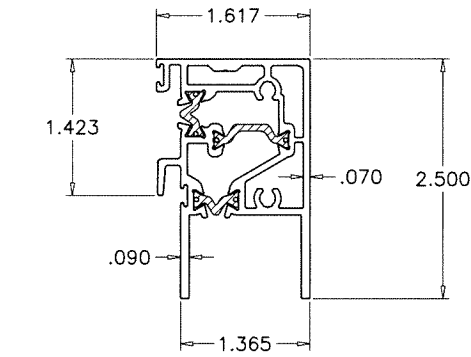

E10 VENT TOP RAIL

TECATHERM® 66 GF INSULBARS  
SCALE 1:1

MATERIAL = POLYAMIDE  
TENSILE STRENGTH = 13031 PSI  
RATE OF BURN = .752 IN./MIN.  
SELF IGNITION TEMP. = 793° F  
FLASH IGNITION TEMP. = 781°C  
SMOKE DENSITY = 1.63

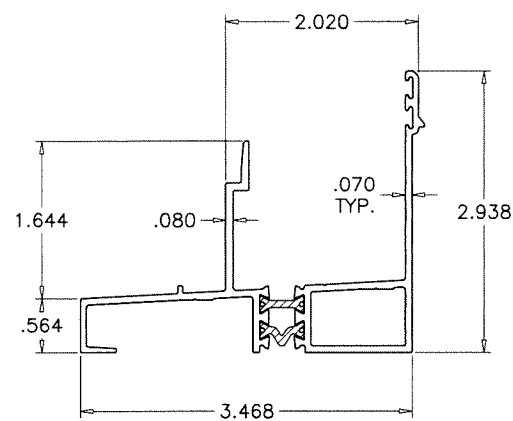

E05 FLUSH FRAME SILL

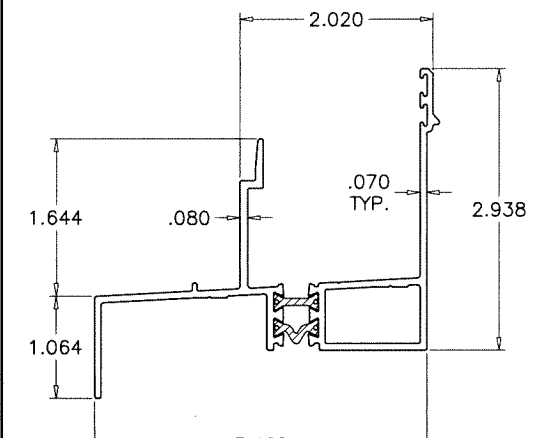

E08 FLANGE FRAME SILL

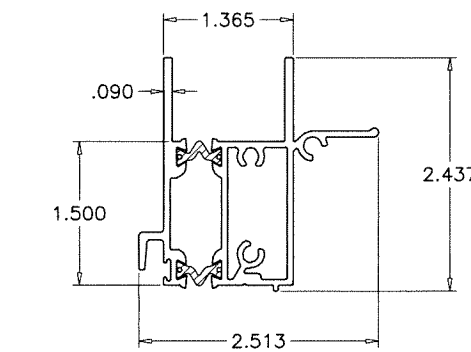

E11 VENT BOTTOM RAIL

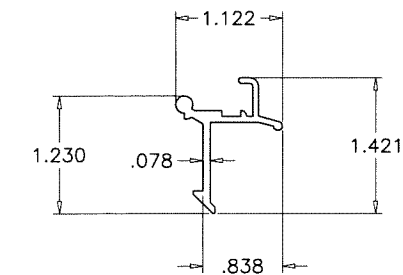

M12 SPRING LOADED LATCH

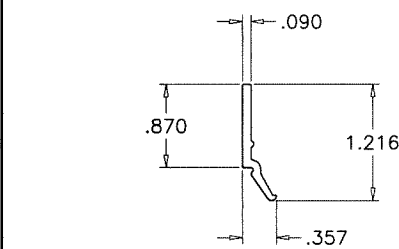

E02 GLAZING BEAD

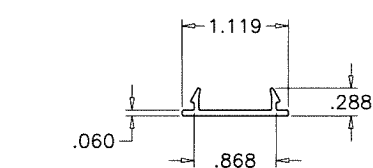

E14 HEAD FRAME COVER

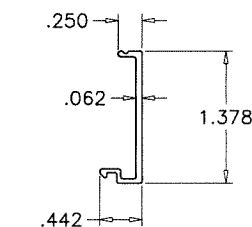

E13 JAMB TRIM

Sealed: 10/18/2023

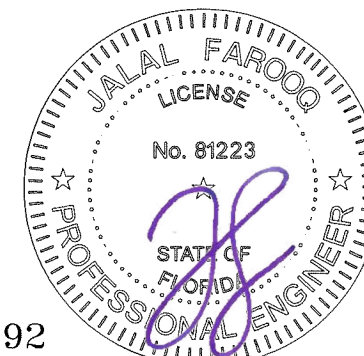

FL #17892

afc

**AL-FAROOQ CORPORATION**  
ENGINEERS & PRODUCT DEVELOPMENT  
9360 SUNSET DRIVE, SUITE 220  
MIAMI, FLORIDA 33173  
TEL. (305) 262-6978  
FAX. (305) 264-8100

ES-H340 THERMAL ALUM SINGLE HUNG WDW. (S.M.I.)

**E.S. WINDOWS, LLC**  
3550 N.W. 49 STREET  
MIAMI, FL. 33142  
TEL. (305) 638-5151 FAX. (305) 638-5158

no	date	by	description

date: 04-12-12  
scale: 1/2" = 1"  
dr. by: TARIQ  
chk. by:

drawing no.

20-41F

sheet 8 of 9

COMP-ANL\20-41F-ES



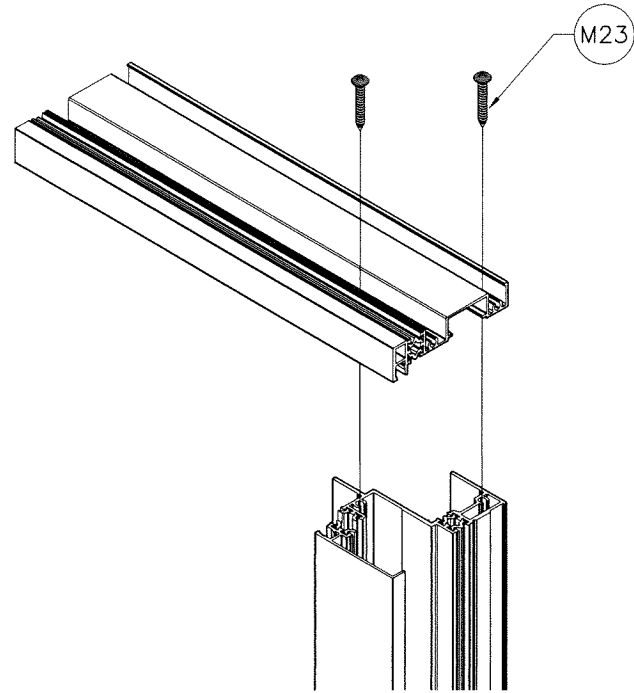

FRAME TOP CORNER

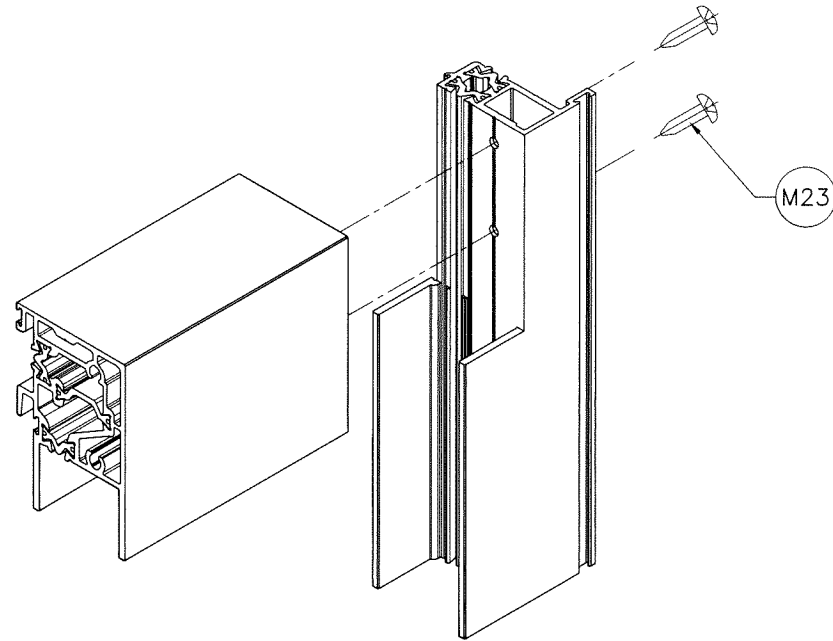

VENT TOP CORNER

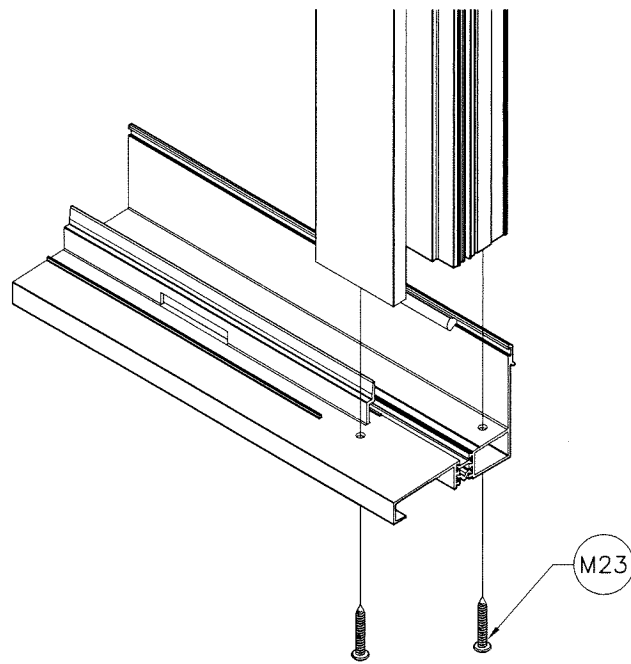

FRAME BOTTOM CORNER

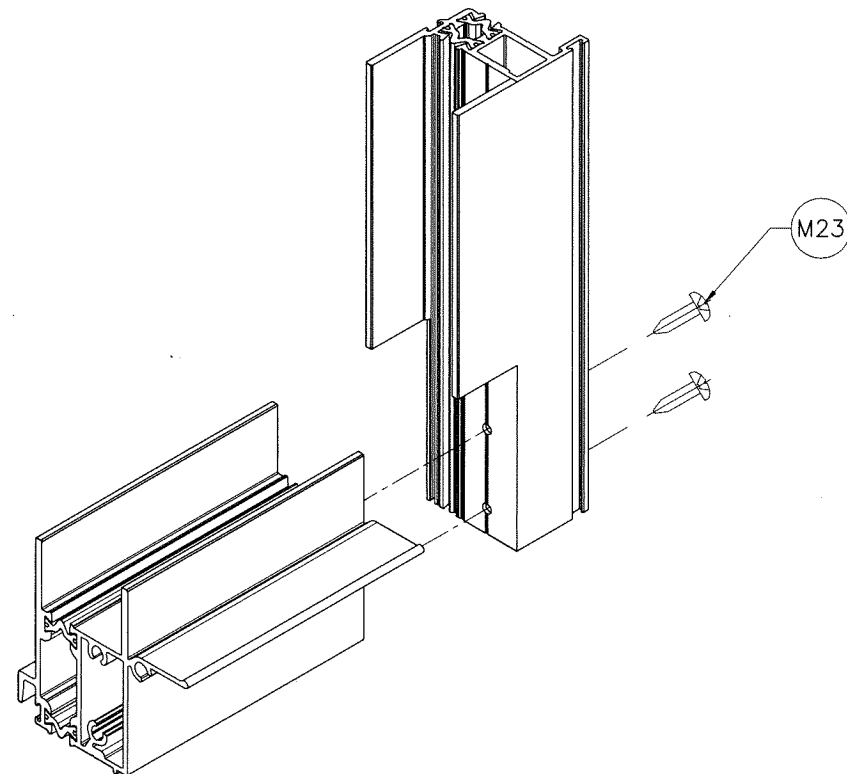

VENT BOTTOM CORNER

Sealed: 10/18/2023

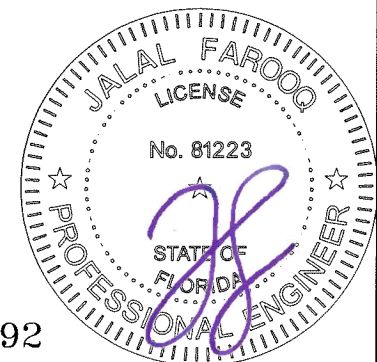

FL #17892

**afc**  
**AL-FAROOQ CORPORATION**  
 ENGINEERS & PRODUCT DEVELOPMENT  
 9360 SUNSET DRIVE, SUITE 220 (C.A.N. 3538)  
 MIAMI, FLORIDA 33173  
 TEL. (305) 264-8100 FAX. (305) 262-6978  
 COMP-ANL\20-41F-ES

ES-H340 THERMAL ALUM SINGLE HUNG WDW. (S.M.I.)  
**E.S. WINDOWS, LLC**  
 3550 N.W. 49 STREET  
 MIAMI, FL. 33142  
 TEL. (305) 638-5151 FAX. (305) 638-5158

revisions:	no	date	by	description

date: 04-12-12  
 scale: 1/2" = 1"  
 dr. by: TARIQ  
 chk. by:

drawing no.  
**20-41F**  
 sheet 9 of 9